



30, rue Pierre-Georges LATECOERE
 05130 TALLARD – FRANCE
 Tel: +33 (0)4 92 20 16 19 Fax: +33 (0)4 92 52 69 66
 e-mail: contact@beringer-aero.com

SERVICE BULLETIN

SB-019

	Description	Date	Approval
0	Initial Revision	25 November 2020	
1	Effectivity correction	15 April 2021	

	Europe	USA
Contact:	BERINGER AERO 30, rue Pierre-Georges LATECOERE 05130 TALLARD – FRANCE	BERINGER AERO USA 400 Birnie Street – Suite E Greenville, SC 29611
Technical Support:	+33 492 201 619 support@beringer-aero.com	(864)-214-4274 support@beringer-aero-usa.com

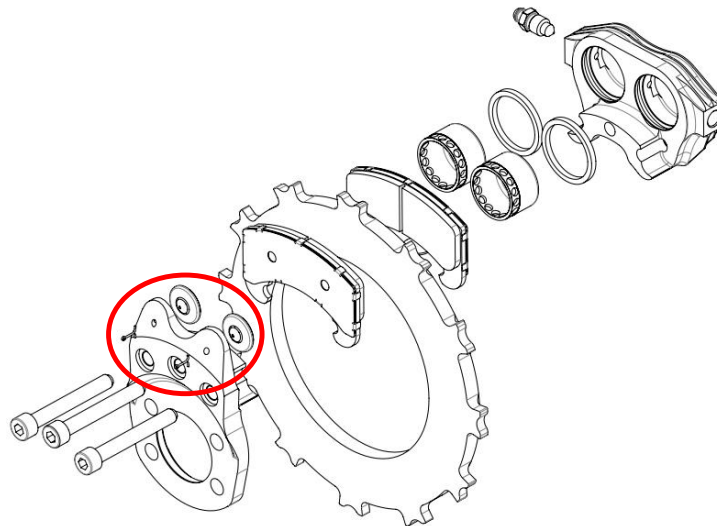

Table of Contents

1.	EFFECTIVITY	2
2.	PURPOSE.....	3
3.	BACKGROUND.....	3
4.	COMPLIANCE	4
5.	INSTRUCTIONS	5
5.1	INSPECTION.....	5
5.2	REPLACEMENT OF COTTER PINS	6



30, rue Pierre-Georges LATECOERE
05130 TALLARD – FRANCE
Tel: +33 (0)4 92 20 16 19 Fax: +33 (0)4 92 52 69 66
e-mail: contact@beringer-aero.com

SERVICE BULLETIN

SB-019

1. EFFECTIVITY

This service bulletin has to be applied to the following products:

P/N	Affected S/N or batches (prior or equal to)
EA-003.3N	5781 *
EA-003.4N	532
EA-003.5N	206
EA-003.7N	052
EA-003.10N	009
EA-004.1N	001
EA-004.2NL & NR	020
EA-004.3NL & NR	042 (NL) & 043 (NR)
EA-004.4NL & NR	All
EA-004.5NL & NR	002

*Nota: 5600.1 to 5653.1 are already equipped with the new solution (no need to apply this SB)



30, rue Pierre-Georges LATECOERE
05130 TALLARD – FRANCE
Tel: +33 (0)4 92 20 16 19 Fax: +33 (0)4 92 52 69 66
e-mail: contact@beringer-aero.com

SERVICE BULLETIN

SB-019

2. PURPOSE

Replacement of Backstop BTR-001 in order to put the cotter-pin (ISO1234) backward. The goal is to prevent scratching of the inner wheel half by the tails of the cotter pin.

Backstop BTR-001(B) supersedes BTR-001(A) to allow this modification.

3. BACKGROUND

The cotter pin securing the back stop on the brake assembly back plate can be displaced from the as installed position. This can occur during unpackaging and first installation, maintenance, or at any other time when the parts are handled. If the cotter pin tails are raised from the surface of the back plate or rotated 90° from the initial orientation then they are at risk for contacting the inner wheel half and scratching the anodized finish.

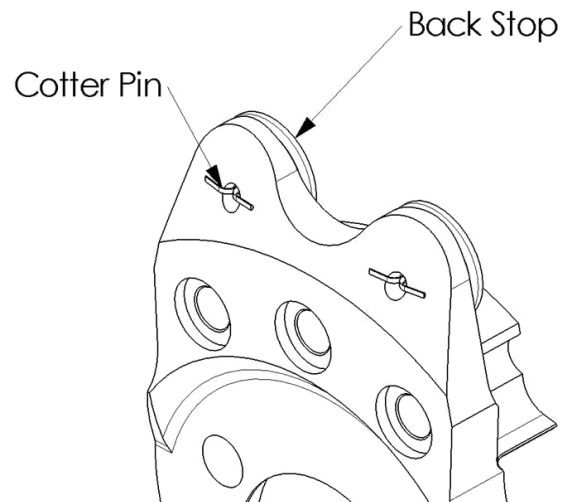

4. COMPLIANCE

At the next annual inspection or change of brake disc, brake pad, or tire [Whichever occurs first].

The occurrence of this scratch is not an airworthiness or safety issue. To prevent damage to the wheel half, it is recommended to inspect the cotter pins as soon as practical.

5. INSTRUCTIONS

5.1 Inspection

- Remove the wheel and tire assembly per the instructions in the applicable maintenance manual.
- Inspect the inner wheel half for circular scratches. An inner wheel half with a continuous circular scratch that has removed the anodizing must be replaced.



- This scratch has been caused by cotter pins that have been displaced from the initial orientation which is set and controlled during manufacturing.



5.2 Replacement of backstop + cotter-pin

- Remove the existing cotter pins.
- Clean the indent in the backplate using water with soap or cleaning solvent and wipe dry with a clean cloth.

CAUTION: Do not use basic or acid agent on wheel halves. Anodizing can be totally removed within few minutes in contact with basic agent. Make sure that cleaning soap is not basic.

- Lubricate the contact area between back stops and back plate with silicone grease
NOTE: Use silicone grease (-50°C to 200°C) compliant with FDA CFR art. 178.3570 (liquid grease in spray is not allowed) or SAE-AS8660 or MIL-S-8660C
- Install new backstop design with a new cotterpin installed in the other direction (see below).
The “eye” of the cotter-pin must be out of the brake caliper.

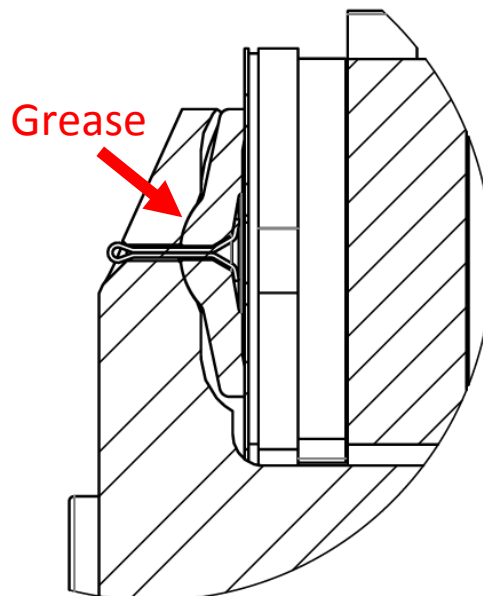

- Use something to push on the cotter-pin in order to bend the tails (without play).
A pin remover is ideal to push the cotter pin. A flat screwdriver works well for bending each tail.



- Re-install caliper and wheel per the instructions in the applicable maintenance manual.

END